

MANAGING PCBs IN SCHOOLS

POLYCHLORINATED BIPHENYLS (PCBs)

PCBs are a group of chemicals that were commonly used in manufacturing and construction. Unfortunately, they affect human health and the environment.



PCBs were banned in 1979, but many schools built or renovated between 1950 and 1979 still contain PCBs.

PCBs take a very long time to break down in the environment. Between 1950 and 1979, many building materials like light fixtures, caulk, adhesives, window glazing and paint were made using PCBs.



It is estimated that between 1/4 and 1/2 of the 48,000 schools built or renovated between 1950 and 1979 may have used these materials containing PCBs.

WHY ARE PCBs A PROBLEM?

PCBs build up in the body over many years.

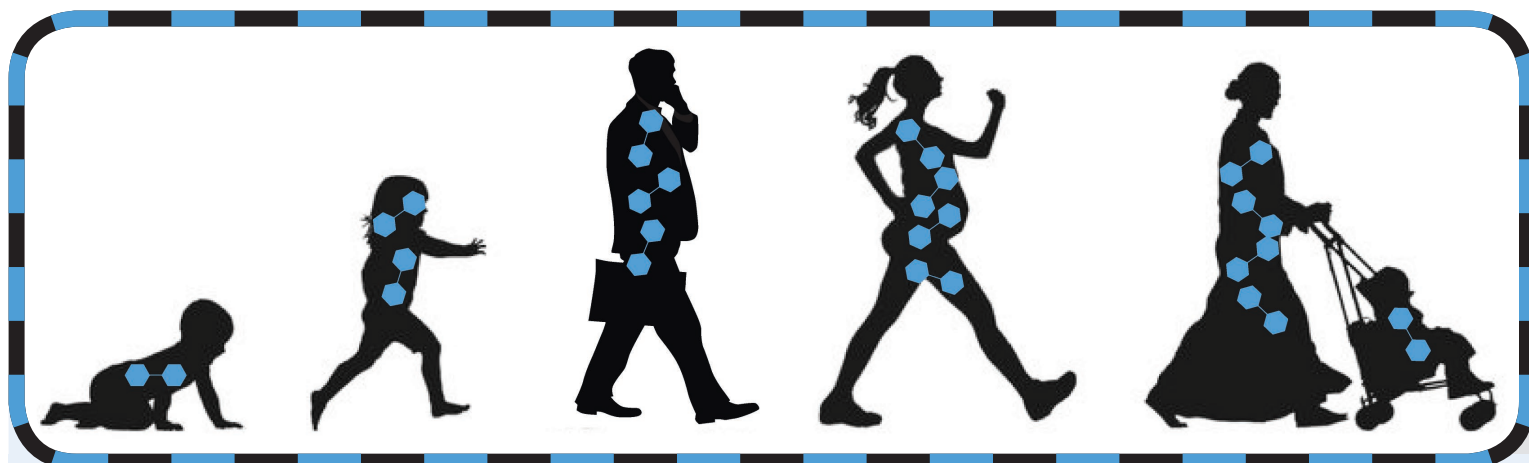

We are all exposed to very small amounts of PCBs through our food and air. We are still learning about all the ways that PCBs may affect our health. Some of the health effects that may be related to PCB exposure include:



- neurodevelopment problems in children
- cancer
- problems in the immune system and in the endocrine system

Pregnant teachers and staff are a concern because: Exposures to even low levels of toxic chemicals during pregnancy may affect the developing brain.

HOW DO WE KNOW IF OUR SCHOOL CONTAINS HARMFUL LEVELS OF PCBs?

If your school was built between 1950 and 1979 and there is concern that PCBs are present, the EPA recommends implementing best management practices. If there is still concern, test the air. Before any building renovations are started in these schools, assume PCBs are present unless testing shows they are not.

HOW CAN CHILDREN AND STAFF BE EXPOSED TO PCBs IN SCHOOLS?

When PCB-containing building materials age, they may release PCBs into dust on surfaces, or into the air.



Children and staff can be exposed by:

- inhaling PCBs in the air into their lungs.
- touching contaminated surfaces and absorbing PCBs through the skin.
- putting their hands in their mouths and ingesting (eating) PCBs in dust.



WHAT CAN WE DO ABOUT PCBs IN SCHOOLS?

The most effective thing you can do is safely remove the materials that contain PCBs. Adopting good building management practices will also reduce the risk.

- Remove old fluorescent light fixtures that contain PCBs.
- If it is possible to remove other building materials, this will further reduce PCBs.
- Prior to renovations, review the EPA fact sheet *Practical Actions for Reducing Exposure to PCBs in Schools and Other Buildings*.
- Increase building ventilation.
- Until you can renovate, use best management practices to lower PCBs on surfaces and in dust.

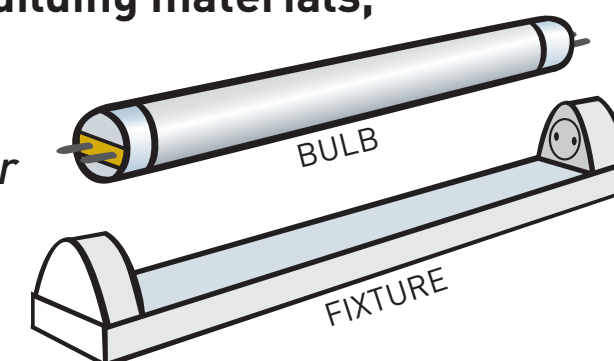

START A GREEN CLEANING PROGRAM!

It will help reduce the risk of exposure to PCBs, and also reduce the risk of exposure to allergens and toxic chemicals commonly found in dust.

Choosing cleaning products certified by an independent third party agency is safer and reduces exposure to toxic chemicals often found in cleaning products.



Clean the floor, walls, and window sills regularly with wet microfiber mops and cloths.



- Removing PCB particles from surfaces reduces exposure through skin contact.
- Do not use dry brooms or dry cloths for dusting—they just stir particles into the air.



- Wash hands with soap and water often, particularly before eating and drinking to prevent ingestion of dust on hands.
- Wash toys frequently with soap and water.
- Use a vacuum with a HEPA filter to reduce dust containing PCBs, allergens and other toxic chemicals found in dust.
- Increase ventilation to remove PCB containing air and bring outdoor air into the building. This reduces exposure to PCBs through inhalation. The EPA's *Indoor Air Quality Tools for Schools Action Kit* is a great place to start.
- Ensure ventilation systems are operating as designed to maintain adequate fresh air flows. Change filters per manufacturer recommendation. In some schools lowering PCB levels in air through ventilation may be too costly. Replacing windows/caulk in these cases will provide energy savings and save money.



Resources

EPA Regional PCB Coordinators
<http://tinyurl.com/zt3dnwy>
EPA PCBs Home Page
www.epa.gov/pcbs
Contains Information on:

- EPA guidelines for disposal of PCB construction waste
- fluorescent ballasts removal
- evaluation of PCBs in Indoor School Air
- caulk removal

ATSDR, Public Health Statement: PCBs
<http://tinyurl.com/zrpsn4q>

EPA Indoor Air Quality Tools for Schools Action Kit <http://tinyurl.com/haefu5s>

Green Cleaning, Sanitizing and Disinfecting: A Toolkit for Early Care and Education
<http://tinyurl.com/z82z54x>

EPA's Safer Choice Program (third party certified cleaning products)
www.epa.gov/saferchoice



Green Seal (third party certified cleaning products) www.greenseal.org

Western States Pediatric

Environmental Health Specialty Unit fact sheet, *PCBs in Schools*
wspesu.ucsf.edu/pcbinschools



This material was supported by the American College of Medical Toxicology (ACMT) and funded (in part) by the cooperative agreement FAIN: U61TS000238-03 from the Agency for Toxic Substances and Disease Registry (ATSDR).

Acknowledgement: The U.S. Environmental Protection Agency (EPA) supports the PEHSU by providing partial funding to ATSDR under Inter-Agency Agreement number DW-75-9587701. Neither EPA nor ATSDR endorse the purchase of any commercial products or services mentioned in PEHSU publications.